

Al Bawadi Primary Model school, Abu Dhabi
Cycle - 2

EOT- 1 Exam Coverage 2022 -2023

Grade 5_ General
Mathematics

Teacher :ABHILASH NELLIKKODEN

Question 1: Determine volume by multiplying the number of unit cubes in one layer by the number of layers that fill a solid with no gaps or overlaps.

3.

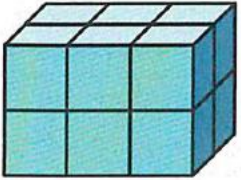

Number of layers: _____

Number in each layer: _____

Volume: _____ cubic units

4.

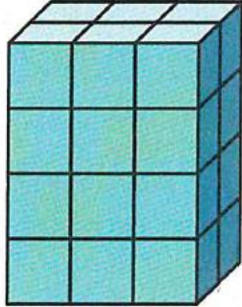

Number of layers: _____

Number in each layer: _____

Volume: _____ cubic units

5. How can you determine the volume of the box?

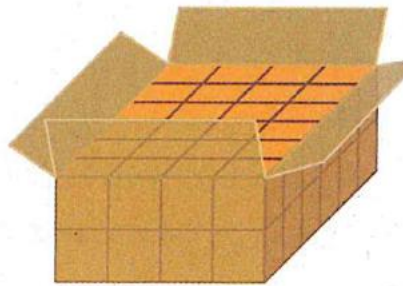

What is the volume of the figure?

6.

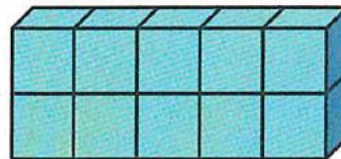

_____ cubic units

7.

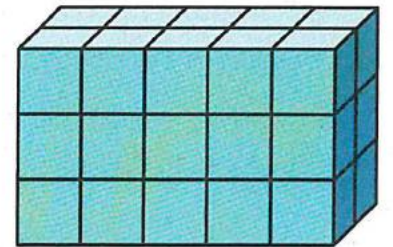

_____ cubic units

What is the volume of the figure? Tell which volume formula you used and why.

3.

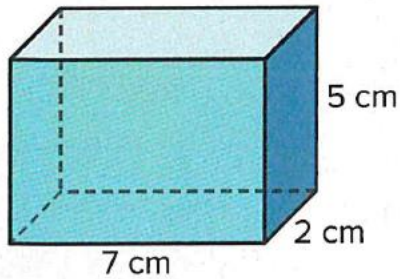

4.

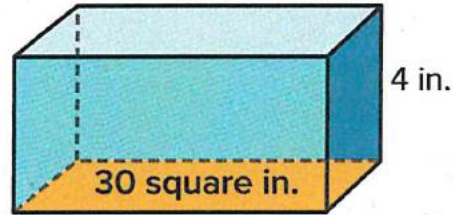

5.

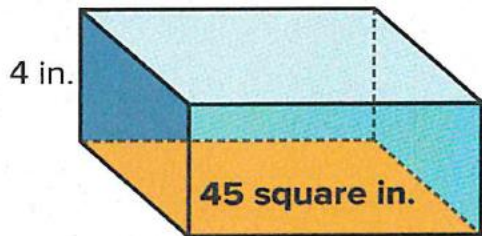

6.

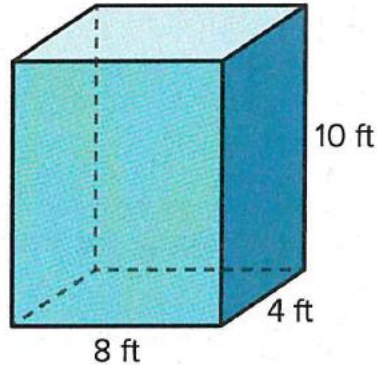

Which expression(s) can be used to determine the volume of the rectangular prisms shown? Select all that apply. Do not actually find the volume of the prism.

2.

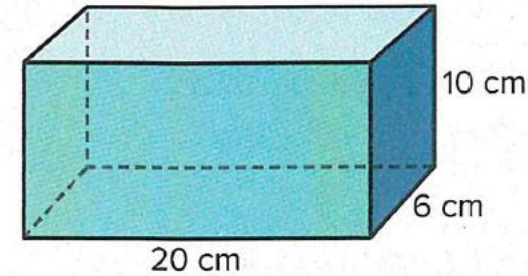

- a. $20 + 6 + 10$
- b. 60×20
- c. $(10 + 6) \times 20$
- d. $20 \times 6 \times 10$
- e. $(20 \times 6) + (6 \times 10)$

Question 3: Find the volume of composite figures

Page Number: 49 Exercise 2 - 5

What is the volume of the figure?

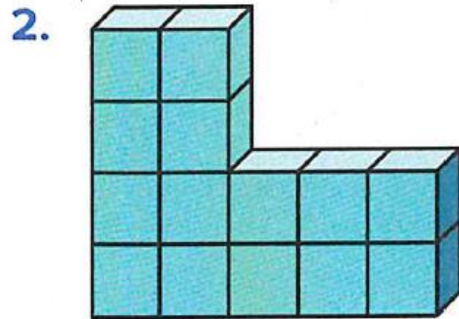

$V =$ _____ cubic units

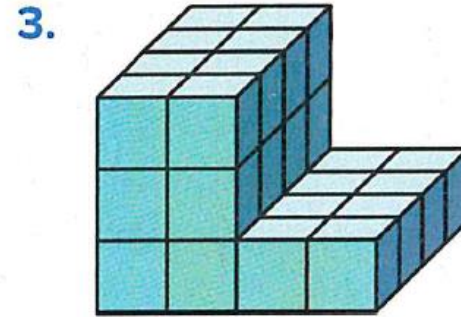

$V =$ _____ cubic units

Draw line(s) to show how you decomposed the figure.

What is the volume of the figure?

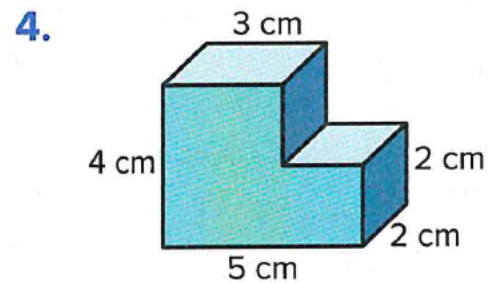

$V =$ _____

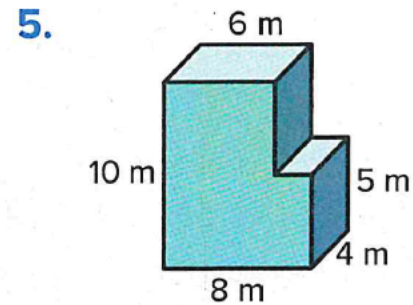

$V =$ _____

Question 4: Explain the relationship of place values in decimal numbers.

Page Number: 69; Exercise 1 - 6

Page Number: 70; Exercise - 10

1. Which of the following statements is *true*?
 - A. 0.009 is ten times 0.09
 - B. 0.09 is ten times 0.009
 - C. 0.09 is $\frac{1}{10}$ of 0.009
 - D. 9 is $\frac{1}{10}$ of 0.9
2. Which of the following statements is *true*?
 - A. 0.003 is $\frac{1}{10}$ of 0.03
 - B. 0.03 is $\frac{1}{10}$ of 0.003
 - C. 0.3 is ten times 0.003
 - D. 3 is ten times 0.03

10. For which numbers is the value of the digit 8 ten times the value of the digit 8 in the number 4.984?
 - A. 3.814
 - B. 5.820
 - C. 6.982
 - D. 8.492

Marcella has \$5.00, Niko has \$0.50, and Benjamin has \$0.05.
Use this information to complete each sentence.

3. Benjamin has _____ the money Niko has.
4. Marcella has _____ the money Niko has.

Complete each sentence.

5. \$9.00 is _____ \$0.90.
6. \$0.90 is _____ \$9.00.

Page Number: 73; Exercise 5 - 12

What is the standard form of the decimal?

5. $0.9 + 0.03 + 0.007$

6. $20 + 0.7 + 0.08 + 0.006$

7. $5 + 0.01 + 0.009$

8. $7 + \frac{4}{10} + \frac{5}{1,000}$

What is each decimal in standard form?

What is each decimal in expanded form?

9. ninety-three and six thousandths

10. three and eight hundred forty-six thousandths

11. two hundred twelve and fifteen thousandths

12. seven hundred fifty-one thousandths

Question 6: Estimate sums and differences of decimals

Page Number: 95; Exercise 1 - 8

What is a reasonable estimate for the sum or difference?

Explain the strategy you used.

1. $9.86 + 4.30$

____ + ____ = ____

2. $43.85 + 56.01$

____ + ____ = ____

3. $3.92 + 6.14$

____ + ____ = ____

4. $24.73 + 26.05$

____ + ____ = ____

5. $8.32 - 5.9$

____ - ____ = ____

6. $88.4 - 10.96$

____ - ____ = ____

7. $16.28 - 5.9$

____ - ____ = ____

8. $5.42 - 1.7$

____ - ____ = ____

Question 7: Represent addition of decimals using decimal grids

Page Number: 101; Exercise 1 - 10

Page Number: 102; Exercise 11

What is the sum? Use the decimal grids.

1. $0.7 + 0.1 =$ _____

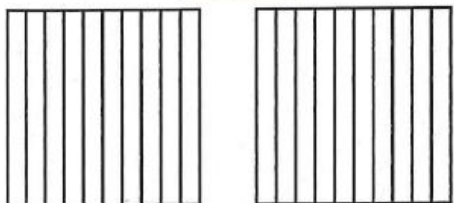

2. $0.5 + 0.8 =$ _____

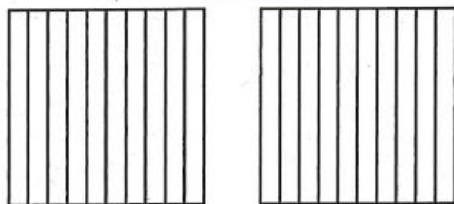

3. $0.02 + 0.09 =$ _____

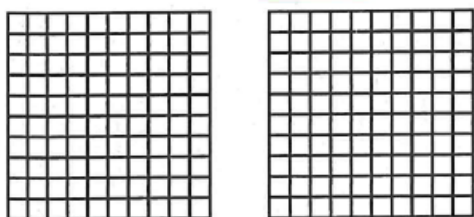

4. $0.78 + 0.64 =$ _____

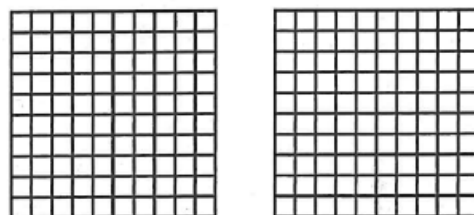

What is the sum? Use decimal grids to show the sum.

5. $0.2 + 0.7 =$ _____

6. $0.5 + 0.6 =$ _____

7. $0.08 + 0.06 =$ _____

8. $0.79 + 0.84 =$ _____

9. $0.32 + 0.88 =$ _____

10. $0.46 + 0.29 =$ _____

11. Write the addition equation represented by the decimal grids.

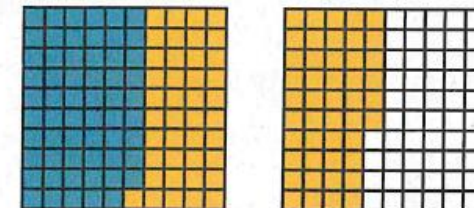

Question 8: Represent subtraction of decimals less than 1 containing tenths

Page Number: 113; Exercise: 5,6

What is the difference? Use a number line to solve.

5. $0.7 - 0.2 =$ _____

6. $0.6 - 0.4 =$ _____

Question 9: Use strategies to subtract decimals

Page Number: 113; Exercise: 5,6

What is the difference? Show your work.

5. $36.33 - 32.29 =$ _____

6. $48.56 - 18.21 =$ _____

7. $17.10 - 6.02 =$ _____

8. $25.50 - 11.49 =$ _____

Question 10: Add and subtract decimals to solve problems

Page Number: 125; Exercise: 7,8

- Carlos' luggage weighs 15.6 pounds. Emily's luggage weighs 19.25 pounds. What is the total weight of their luggage? Which strategy did you use to solve?
- Amy drove 13.4 miles on Monday and 11.25 miles on Tuesday. How much farther did she drive on Monday than on Tuesday? Which strategy did you use to solve?

Page Number: 126; Exercise: 10, 12

- A rectangular poster in a stadium measures 13.25 meters on two sides and 9.5 meters on two sides. What is the perimeter of the poster?
- The science club raised money to clean the beach. They spent \$29.75 on trash bags and \$74.75 on waterproof boots. They still have \$47 left. How much did they raise?

Question 11: Write a power of 10 using a base of 10 and exponents.

Page Number: 137; Exercise: 9 - 12

Write the exponential form of each power of 10.

9. $10 =$ _____

10. $1,000 =$ _____

11. $100 =$ _____

12. $10,000 =$ _____

Question 12: Use an area model and partial products to multiply multi-digit whole numbers.

Page Number: 149; Exercise: 1 - 8

Complete the area model. Then solve to find the product.

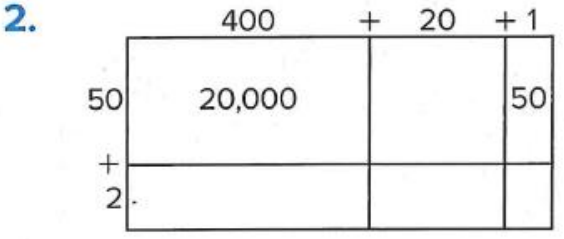
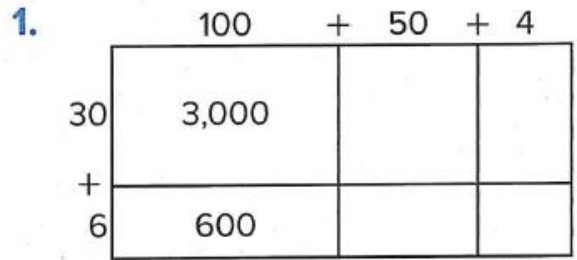

Write the multiplication equation based on the area model. Then solve to find the product.

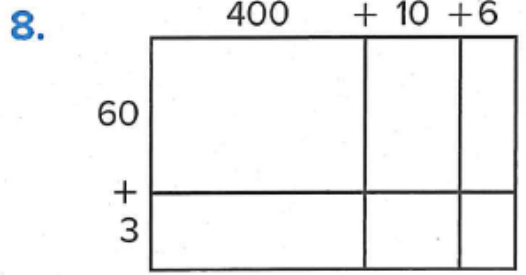
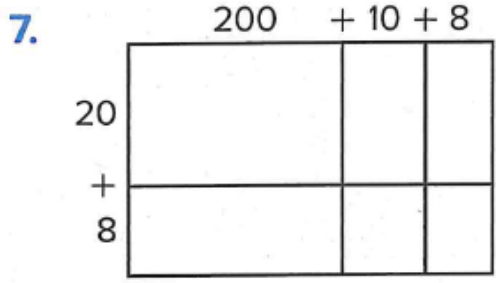

What is the product? Use area models to solve.

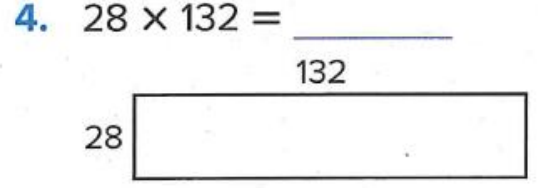
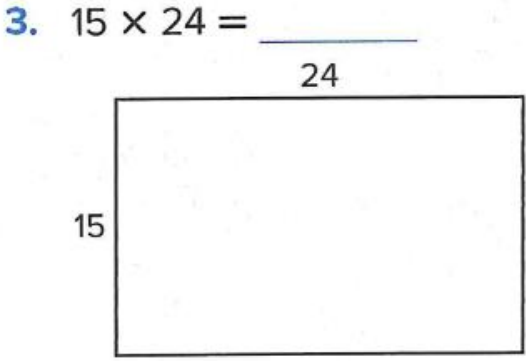

5. $33 \times 78 = \underline{\hspace{2cm}}$

6. $72 \times 225 = \underline{\hspace{2cm}}$

Question 13: Multiply using an algorithm

Page Number: 157; Exercise: 1 - 8

What is the product?

1.
$$\begin{array}{r} 327 \\ \times 6 \\ \hline \end{array}$$

2.
$$\begin{array}{r} 543 \\ \times 8 \\ \hline \end{array}$$

3.
$$\begin{array}{r} 1,931 \\ \times 5 \\ \hline \end{array}$$

4.
$$\begin{array}{r} 3,462 \\ \times 4 \\ \hline \end{array}$$

What is the product? Choose the correct answer.

5. $188 \times 7 = s$

A. $s = 1,300$

B. $s = 1,316$

C. $s = 1,388$

D. $s = 1,406$

6. $237 \times 9 = v$

A. $v = 2,033$

B. $v = 2,163$

C. $v = 2,153$

D. $v = 2,133$

7. $2,623 \times 2 = y$

A. $y = 5,246$

B. $y = 4,246$

C. $y = 5,126$

D. $y = 5,616$

8. $5,246 \times 3 = r$

A. $r = 15,882$

B. $r = 16,838$

C. $r = 16,612$

D. $r = 15,738$

Question 14: Use an algorithm to multiply multi-digit factors

Page Number: 163; Exercise: 9,10

9. The students at Mia's school use about 3,408 sheets of paper per day. How many sheets of paper do the students use after 25 days of school?
10. In one video game, you can build a house for every 375 points you earn. Jack built 23 houses. How many points did he earn?

Page Number: 164; Exercise: 11, 12

11. On a road trip, a family traveled 412 miles each day. How many miles had they traveled by the end of 5 days?
12. A hotel room costs \$193 per night. How much will a 7-day stay cost?

Estimate each product by rounding. Show your work.

1. $5.73 \times 3.16 = ?$

2. $6.23 \times 3.87 = ?$

3. $13.6 \times 9.82 = ?$

4. $40.55 \times 7.89 = ?$

5. $19.91 \times 28.75 = ?$

6. $24.09 \times 12.57 = ?$

What is the product? Use a representation to solve.

5. $8 \times 0.2 =$ _____

7. $0.12 \times 7 =$ _____

9. $5 \times 1.5 =$ _____

6. $0.3 \times 0.9 =$ _____

8. $0.4 \times 0.8 =$ _____

10. $0.6 \times 0.6 =$ _____

11. Write an equation to show the product represented by the decimal grids.



Question 17: Understand a variety of strategies to solve multiplication equations involving decimals.

Page Number: 197; Exercise: 3 – 7

3. Each bottle holds the same amount. How much water can these bottles hold?



5. Experts recommend that people have 4.7 grams of potassium per day. Last week Marcus averaged 0.9 times as much potassium as the recommendation. How much potassium did Marcus average each day last week?

7. Kara has a bag of apples. Each apple weighs 0.4 pound on average. There are 17 apples in her bag. What is the total weight of her apples?

4. Rebecca cut these ribbons to the same length. How much ribbon did Rebecca use in all?

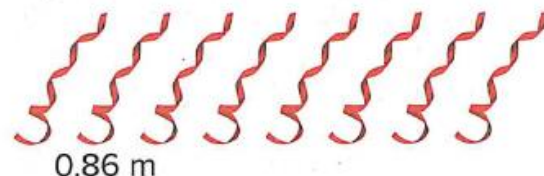

6. A pitcher has a capacity of 3.9 liters. A cooler has a capacity 9.2 times greater. What is the capacity of the cooler?

Page Number: 198; Exercise: 8,9,11

8. Julio's doctor told him that he should eat 0.7 gram of protein per day for every kilogram of body mass. Julio measures 58 kilograms now. How much protein should Julio eat?
9. Anita rode her bicycle 7.8 miles on Monday and 3.1 times as far on Tuesday. How far did she ride her bicycle on Tuesday?
11. Jared buys 3.5 pounds of potatoes. The store charges \$0.80 per pound of potatoes. How much does Jared pay for the potatoes? Explain how you solved the problem.

Question 18: Use patterns to determine the quotient when dividing by a multiple of 10.

Page Number: 209; Exercise: 3 – 10

Page Number: 238; Exercise: 6

3. $20,000 \div 40 =$ _____

4. $15,000 \div 30 =$ _____

5. $18,000 \div 60 =$ _____

6. $16,000 \div 80 =$ _____

7. $8,000 \div 40 =$ _____

8. $25,000 \div 50 =$ _____

9. $32,000 \div 80 =$ _____

10. $9,000 \div 30 =$ _____

6. Which is the quotient? (Lesson 7-1)

$24,000 \div 80$

A. 3

B. 30

C. 300

D. 3,000

Question 19: Use the relationship between multiplication and division to determine the quotient when dividing by a two-digit divisor.

Page Number: 217; Exercise: 5 – 8

Solve for the unknown.

5. $396 \div 12 = n$

$$n \times 12 = 396$$

7. $312 \div 52 = m$

$$m \times 52 = 312$$

6. $448 \div 16 = s$

$$s \times 16 = 448$$

8. $533 \div 41 = a$

$$a \times 41 = 533$$

Page Number: 230; Exercise: 6 – 8

6. Lily's town is hosting a race. She bought 1,525 water cups to pass out to the runners. She wants to distribute the cups equally to 14 water stations. When she finishes, how many are remaining?

7. One bridge in Maryland is 6,946 meters long. It is 46 times as long as another nearby bridge. How long is the shorter bridge? Explain.



8. Amir has a collection of 936 trading cards. He wants to put them in boxes with 25 trading cards in each box. How many boxes will Amir fill? How many trading cards will be left over?